TEA5170 - SECONDARY CONTROLLER FOR MASTER-SLAVE STRUCTURE

By T. PIERRE

SUMMARY		Page
I	INTRODUCTION	2
II	OPERATING PRINCIPLES OF MASTER-SLAVE STRUCTURE	2
II.1	MASTER-SLAVE MODE	2
II.2	BURST MODE	2
II.3	OPERATION OF A MASTER-SLAVE SUPPLY IN TV APPLICATION	3
III	DESCRIPTION OF TEA5170	4
III.1	BLOCK DIAGRAM	4
III.2	OSCILLATOR	5
III.2.1	Operation in Free-Running Frequency Mode	5
III.2.2	Operation in Synchronized Mode	5
III.3	ERROR AMPLIFIER	6
III.4	PULSE WIDTH MODULATION	6
III.5	OUTPUT STAGE	7
III.6	V _{CC} MONITORING	7
IV	TV POWER SUPPLY APPLICATION BUILT AROUND TEA5170	7
IV.1	MAIN APPLICATION CHARACTERISTICS	7
IV.2	COMPONENTS EXTERNAL TO TEA5170	7
IV.3	FREE-RUNNING OSCILLATION FREQUENCY	7
IV.4	ERROR AMPLIFIER COMPENSATION	8
IV.5	SYNCHRONIZATION SIGNAL MATCHING STAGE	8
IV.6	SOFT-START PERIOD DURATION	8
IV.7	TRANSFORMER CHARACTERISTICS	8
IV.8	OPERATION	8
IV.8.1	Start-up	8
IV.8.2	Stand-by	9
IV.8.3	Synchronized Mode	9
IV.9	DELAY TIME IN SYNCHRONIZED MODE	9
IV.10	ELECTRICAL DIAGRAM	10
V	DC-DC CONVERTER	11
V.1	ELECTRICAL DIAGRAM	11
V.2	OPERATION	11
V.2.1	Open-load Protection	11
V.2.2	Short-circuit Protection	11
V.2.3	Demagnetization Monitoring	11
VI	CONCLUSION	12

TEA5170 - SECONDARY CONTROLLER FOR MASTER-SLAVE STRUCTURE

I - INTRODUCTION

The TEA5170 is designed to work in the secondary part of SMPS, sending pulses to the slave TEA2164 which is located on the primary side of the main transformer.

The function of the regulation and synchronization are carried out by the TEA5170.

An accurate regulated voltage is obtained by duty cycle control.

The TEA5170 can be externally synchronized by a frequency higher or lower than the free-running frequency. This feature is particularly suitable for TV applications.

- Master-slave mode (for normal operation)
- Burst mode (used during start-up and stand-by phases)

II.1 - Master-Slave Mode

In this configuration, the master circuit located on the primary side, issues PWM pulses used for output voltage regulation. These pulses are sent via a pulse transformer to the slave circuit (Figure 1). In this mode of operation, the falling edge of PWM signal may be synchronized by an external signal (e.g. by line flyback signal in TV applications).

II.2 - Burst Mode

During start-up and stand-by phases, no regulation pulses are issued by the master circuit and thus the slave circuit operates in burst mode. In this configuration, the slave circuit determines the switching frequency and the burst period (see Figure 2).

II - OPERATING PRINCIPLES OF MASTER-SLAVE STRUCTURE

This architecture offers two modes of operation :

Figure 1

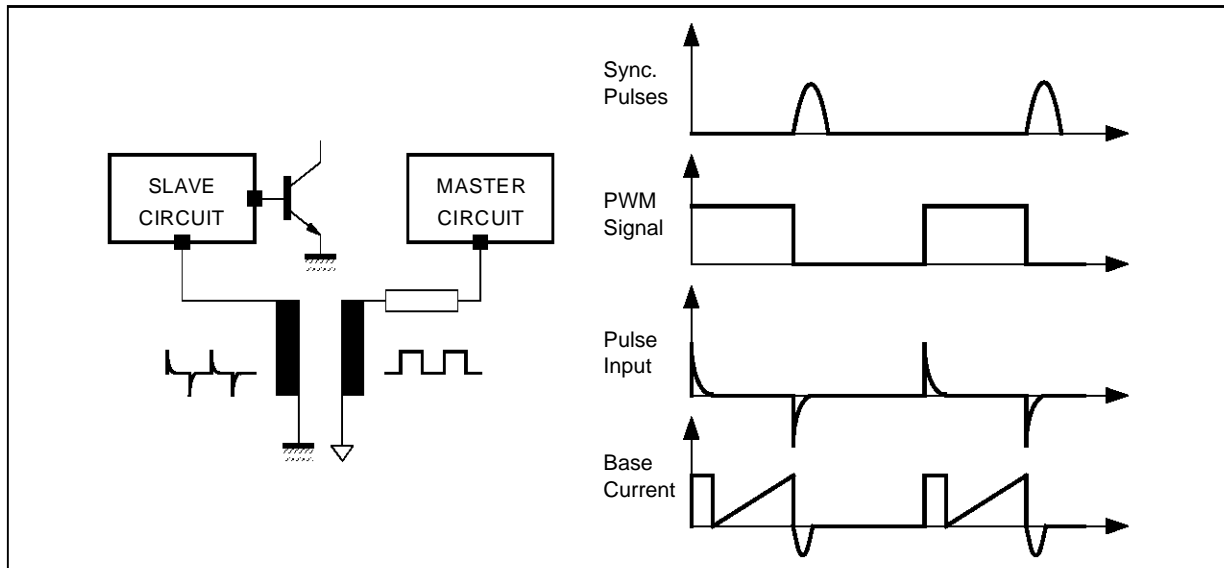

5170-12.EPS

Figure 1

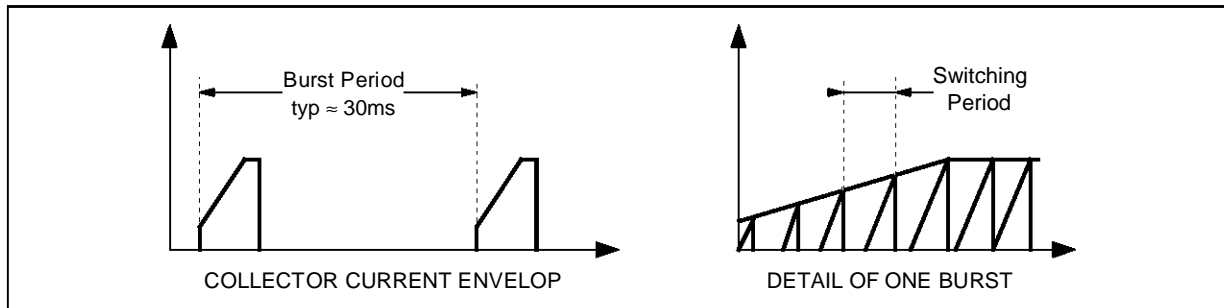

5170-13.EPS

TEA5170 - SECONDARY CONTROLLER FOR MASTER-SLAVE STRUCTURE

II.3 - Operation of a Master-Slave Supply in TV Application

The arrangement generally employed is depicted in Figure 3. On the secondary side, a microcontroller is connected to the remote control receiver which issues control signals for stand-by and normal modes of operation (Figure 4).

- In stand-by mode, the device power consumption is low (few Watts). The master will no longer send any control pulses to the slave which will consequently begin operating in burst mode.
- Power supply regulation is performed by the slave circuit through the auxiliary winding.

- In normal mode of operation, the master circuit issues the PWM signal for regulation. The power supply operates in master-slave mode. The master circuit is simultaneously synchronized with the line flyback signal.

- Power supply start-up. As soon as the V_{CC} (START) threshold is reached, the slave circuit begins operating in burst mode. While the secondary voltages are being stabilized, the microcontroller holds the TV set in stand-by mode.

Once the start-up phase is terminated, the set may remain in stand-by mode or switch into normal mode of operation.

Figure 3

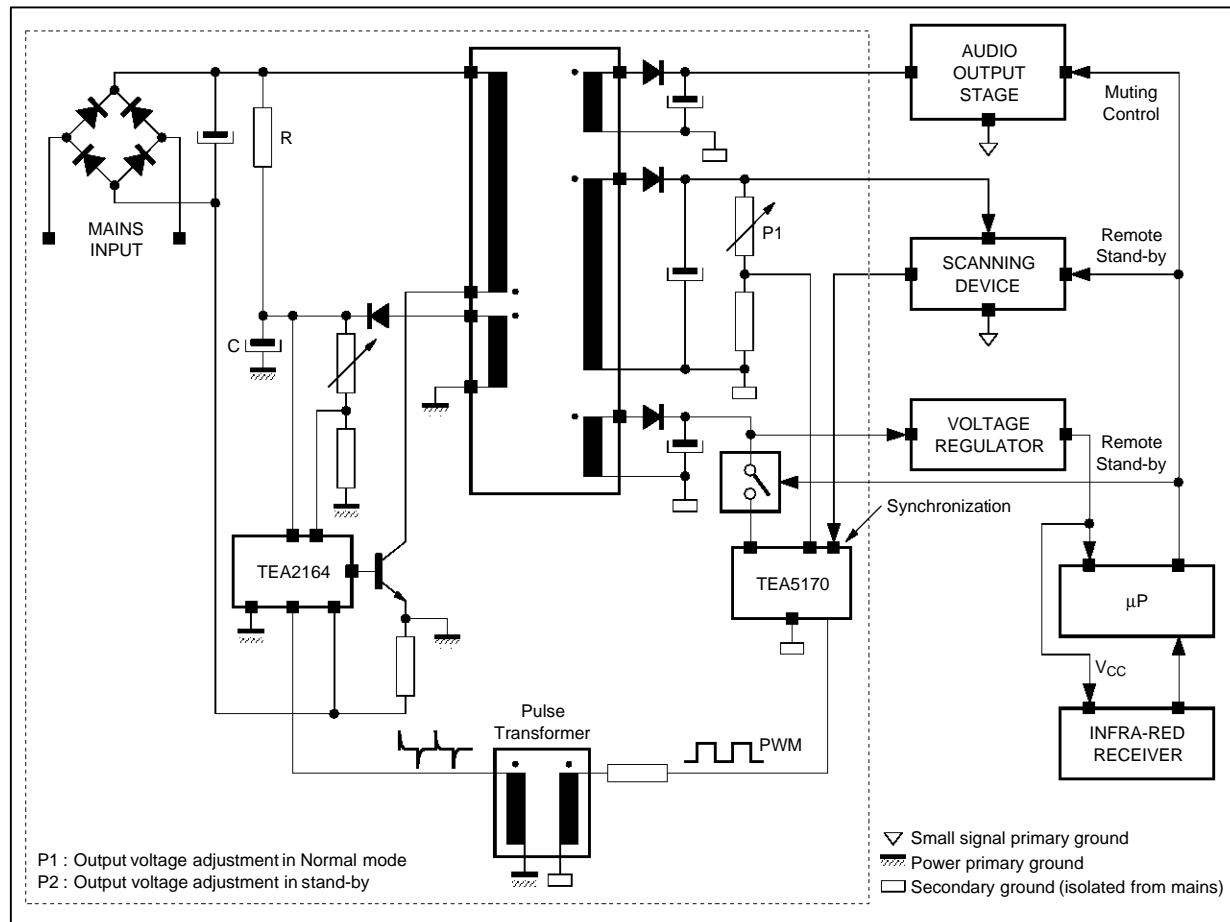

5170-14.EPS

TEA5170 - SECONDARY CONTROLLER FOR MASTER-SLAVE STRUCTURE

Figure 4

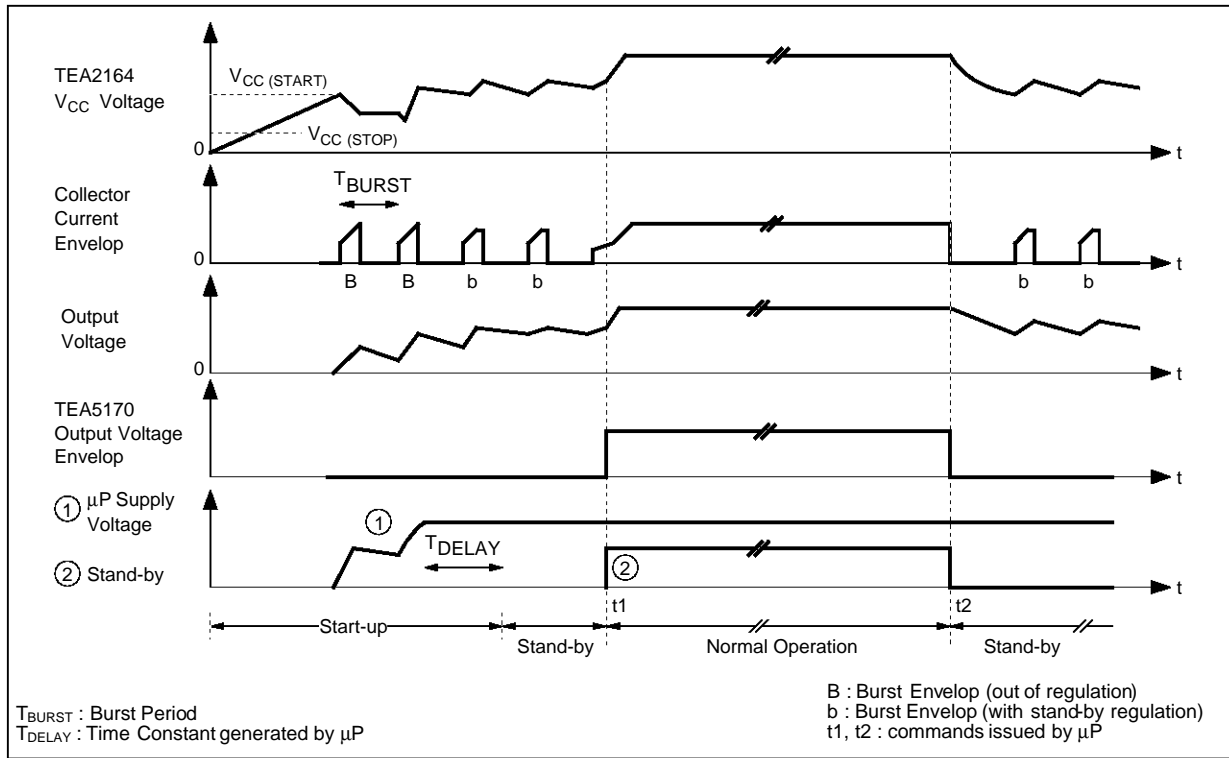

5170-15.EPS

III - DESCRIPTION OF TEA 5170

The TEA5170 is a fixed frequency PWM signal generator operating in voltage mode regulation.

III.1 - Block Diagram

Figure 5 : Block Diagram

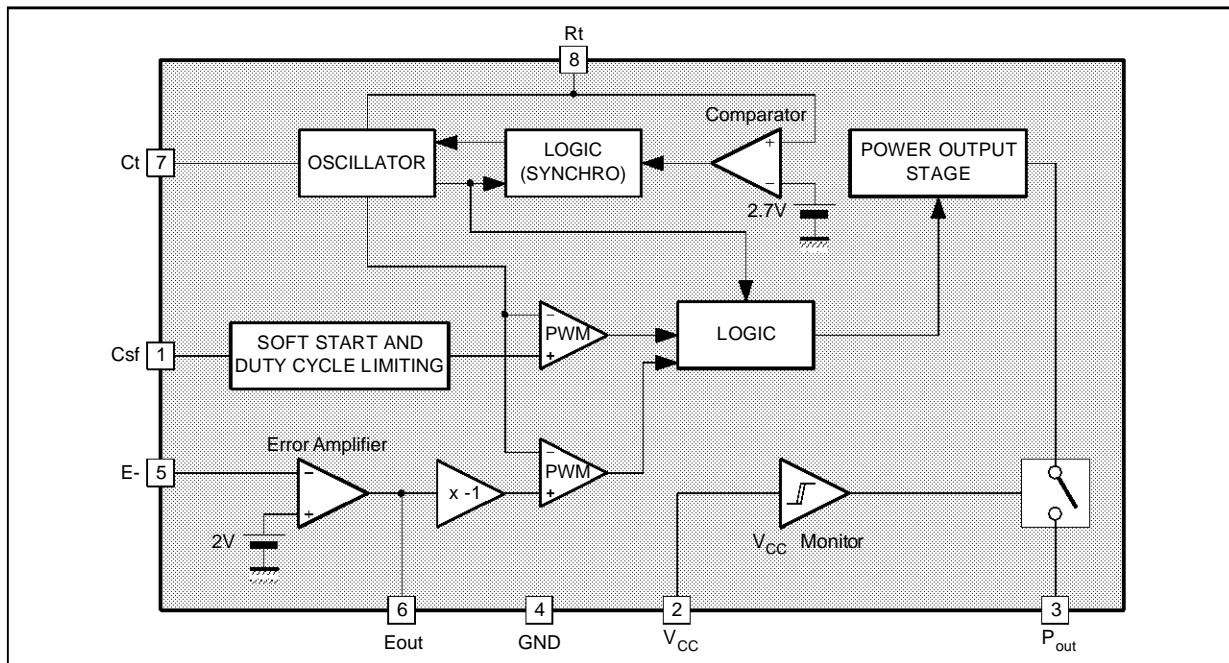

5170-02.EPS

TEA5170 - SECONDARY CONTROLLER FOR MASTER-SLAVE STRUCTURE

III.2 - Oscillator

The oscillator generates a linear saw-tooth signal and sets the free-running frequency. This oscillator can also operate in synchronized mode.

III.2.1 - Operation in free-running frequency mode (See Figure 6)

III.2.2 - Operation in synchronized mode

The oscillator is synchronized by forcing the saw-tooth return.

Enabling the synchronized mode (Figure 7)

The synchronized mode is enabled when the signal pulse on Pin 8 (R_t) coincides with the oscillator saw-tooth return. The " C_t " capacitor charge current is then multiplied by a factor of 0.75.

The TEA5170 will remain in synchronized mode as

long as the synchronization pulses fall within the following window :

$$(0.8 T_1 + T_2) < T_{\text{SYNC}} < (1.33 T_1 + T_2)$$

Where :

- T_1 : C_t charge time in non synchronized mode.
- T_2 : C_t discharge time

Synchronization signal (Figure 8)

Synchronization signal is applied to Pin 8 " R_t " and the capacitor " C_t " is discharged when voltage " V_{Rt} " exceeds the "2.7 V" threshold.

Comment :

The internal current generator used to charge the " C_t " capacitor is disabled for the entire phase where " V_{Rt} " is higher than 2V. Thus, in order to maintain the saw-tooth shape of the oscillator signal, the " V_{Rt} " voltage should fall to 2V before the capacitor " C_t " full discharge.

Figure 6

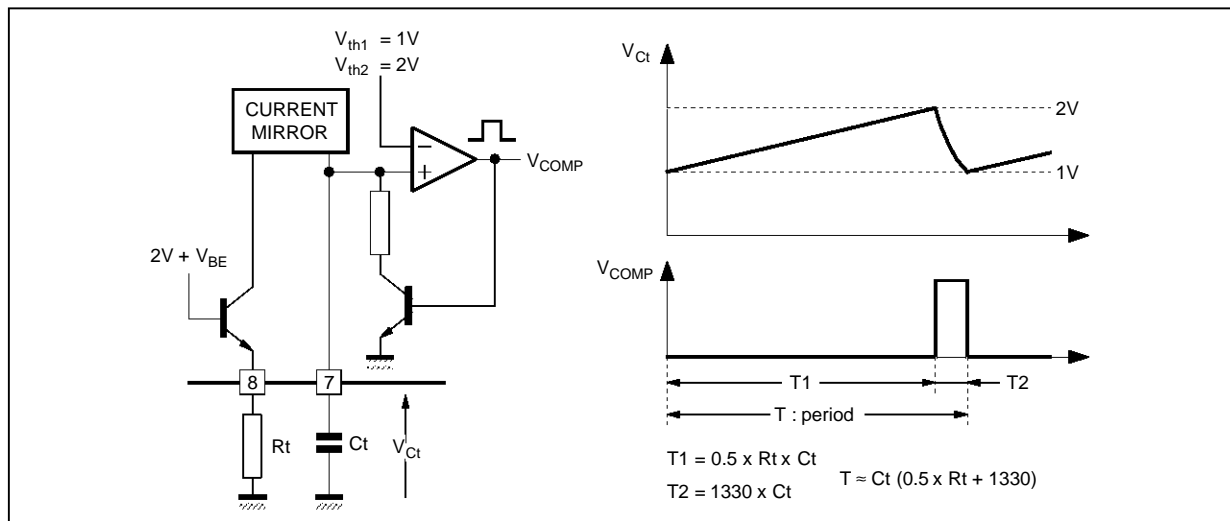

5170-16.EPS

Figure 7

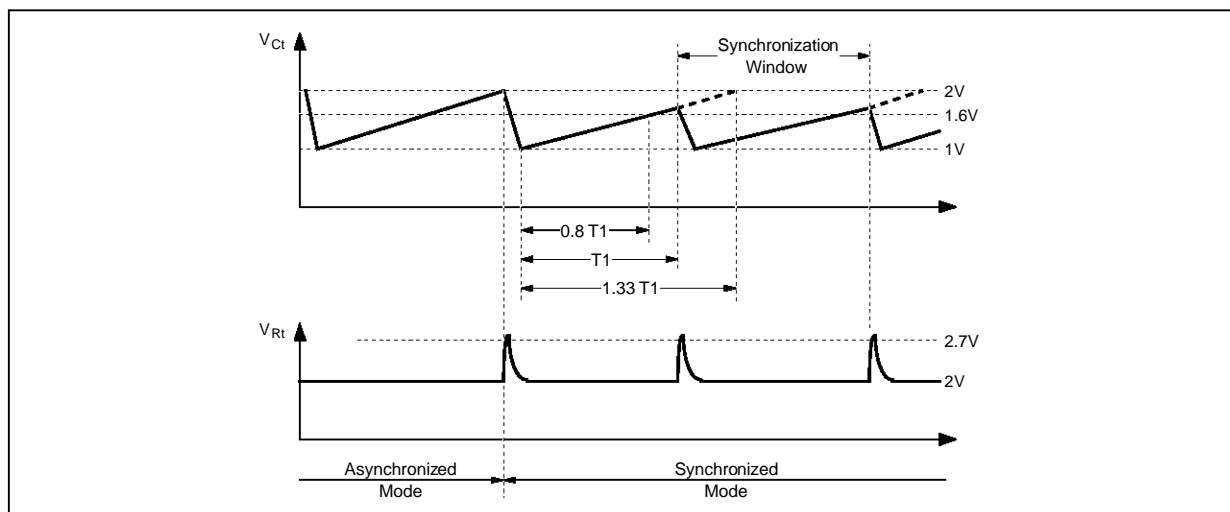

5170-17.EPS

TEA5170 - SECONDARY CONTROLLER FOR MASTER-SLAVE STRUCTURE

Figure 8

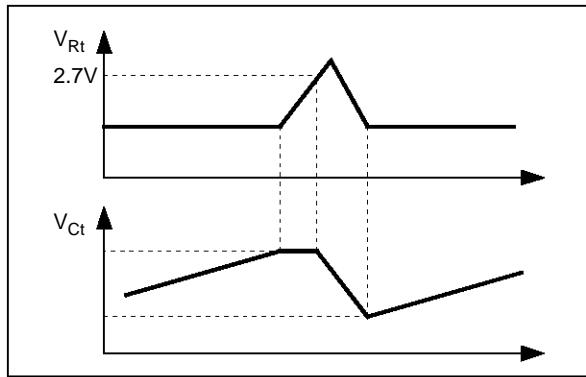

5170-18.EPS

III.3 - Error Amplifier (Figure 9)

The on-chip error amplifier can be accessed through its inverting and output terminals. The non-inverting input is internally tied to reference voltage level.

Figure 9

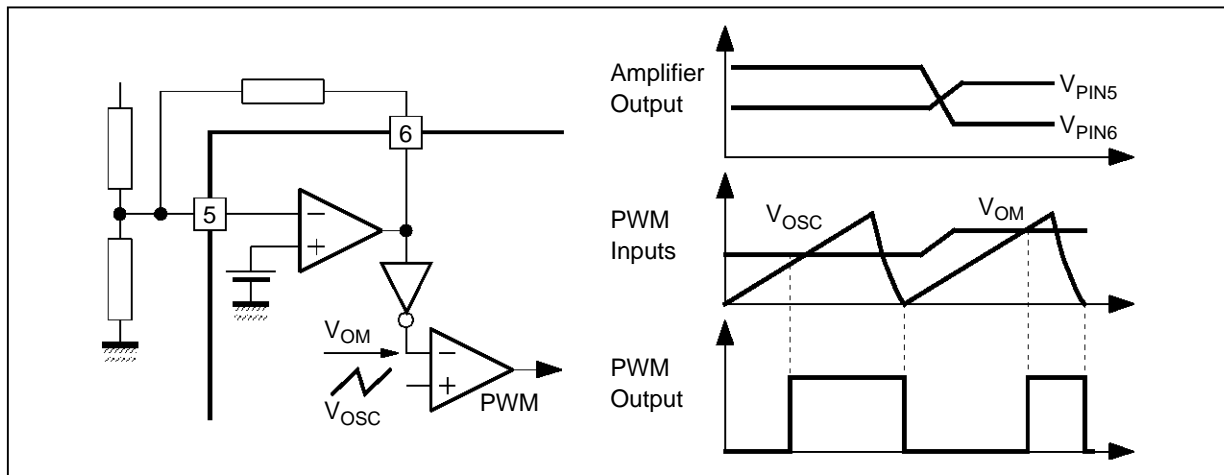

5170-18.EPS

Comment :

An internal inverting amplifier sets the correct phase polarity of the error amplifier output signal for regulation.

III.4 - Pulse Width Modulation (Figure 9)

The TEA 5170 is a PWM signal generator operating in voltage mode. The pulse width is determined by comparing the error signal " V_{OM} " with the oscillator saw-tooth.

When the error signal " V_{OM} " exceeds the regulation range, internal threshold components will set a minimum conduction time $t_{ON (min)}$ and also limit the maximum conduction time $t_{ON (max)}$.

At initial start-up, a soft-start function implemented by linear charge of soft-start capacitor " $C_{(S-START)}$ " is used to vary gradually the $t_{ON (max)}$ threshold. The output pulse width varies from $t_{ON (min)}$ to $t_{ON (max)}$ nominal value for $V_{C(S-START)}$ voltage variation of 0 to 2V.

TEA5170 - SECONDARY CONTROLLER FOR MASTER-SLAVE STRUCTURE

III.5 - Output Stage (see Figure 10)

The output stage operates in on/off mode. For a supply voltage higher than 8V, the output signal value is independent of the supply voltage (typical value : 7V).

Figure 10

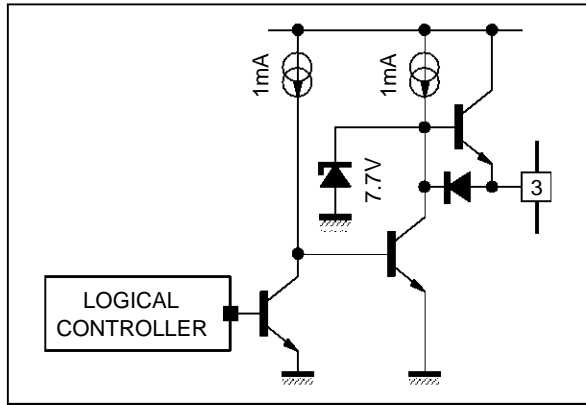

III.6 - V_{CC} Monitoring

V_{CC} Rising :

When V_{CC} reaches the value "V_{CC} (START)", an internal switch enables the operation of the output stage and the soft-start capacitor begins charging. The internal logic circuitry becomes operational before V_{CC} has reached the "V_{CC} (START)" value.

V_{CC} Falling :

When V_{CC} falls below the "V_{CC} (STOP)" level, the negative output stage is switched-on, the transistor is turned off and the soft-start capacitor is discharged.

IV - TV POWER SUPPLY APPLICATION BUILT AROUND TEA5170 (Figure 15)

General structure and operational features of this power supply were outlined in section 1.

The details covered below apply to a power supply configuration using the slave "TEA2164" device.

(Refer to TEA2164 data sheet and application note "AN409/0591" for further details).

IV.1 - Main Application Characteristics

Characteristic	Value
Input voltage	170V _{AC} to 270V _{AC}
Output power	20W to 120W
Output power in stand-by mode	1W to 6W
Switching frequency	32kHz
Synchronization on line flyback signal (positive)	

IV.2 - Components External To TEA5170

Component Value Calculation

Also refer to TEA2164 Application Note "AN-409/0591" for calculation methods applicable to other power supply elements.

The external components determine the following parameters :

- Operating frequency
- t_{ON} (min)
- Soft-start
- Error amplifier gain

Ideal Values

- Period of operation "T_{OSC}" : 32μs
- t_{ON} (min) duration : 1.2μs
- soft-start duration : 20ms
- Error amplifier gain :
DC gain G_{DC} = 35
AC gain at 1/10 x T_{OSC} : G_{AC} = G_{DC}/5 = 7

IV.3 - Free-Running Oscillation Frequency

For efficient use of TEA5170 and TEA2164 synchronization windows, the periods of both devices are determined as follows :

$$T_{OSC(5170)} = \frac{T_{SYNC}}{1.06}$$

$$T_{OSC(2164)} = \frac{T_{OSC(5170)}}{1.223}$$

Where :

- T_{SYNC} : line flyback signal period
- T_{OSC(5170)} : TEA5170 free-running period
- T_{OSC(2164)} : TEA2164 free-running period

Numerical Application

Period of synchronization signal being

T_{SYNC} = 32μs :

$$T_{OSC(5170)} = \frac{T_{SYNC}}{1.06} = 30.2\mu s$$

$$T_{OSC(2164)} = \frac{T_{OSC(5170)}}{1.223} = \frac{30.2}{1.223} = 24.7\mu s$$

The TEA5170 free-running period is determined as follows :

$$T_{OSC(5170)} = C_t (0.5 \times R_t + 1330)$$

Where :

$$C_t = \frac{t_{ON(min)} - 0.5 \times 10^{-6}}{1330}$$

- R_t = 105kΩ (1%)
- C_t = 560 pF (2%)

TEA5170 - SECONDARY CONTROLLER FOR MASTER-SLAVE STRUCTURE

IV.4 - Error Amplifier Compensation

- A high DC gain is required for good accuracy.
- For stability reasons, the AC gain must be attenuated so as to avoid injection of the switching frequency component into the regulation loop.

- DC Gain : $G_{DC} = R3 \times \frac{R2 + R1}{R2 \times R1}$

- AC Gain : $G_{AC} = \frac{R3 \times \frac{1}{j\omega C}}{R3 + \frac{1}{j\omega C}} \times \frac{R2 + R1}{R2 \times R1}$

Assumptions :

- $R2 \gg R1$ since $V_{OUT} > 10 V_{REF}$ so the value of $R2$ does not modify the result of calculation and only $R1$ and $R3$ influence may be taken into consideration.
- $R1 = 2.2k\Omega$, $R3 = 75k\Omega$
- With cut-off frequency in AC regulation mode :
- $f_c = \frac{1}{10 \times T_{OSC}} \Rightarrow C = 2.2nF$

Figure 11

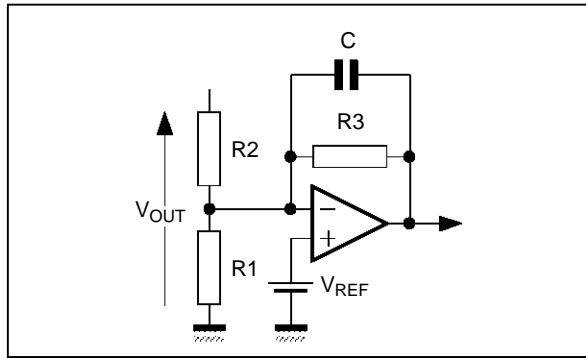

5170-21.EPS

IV.5 - Synchronization Signal Matching Stage (Figure 12)

The synchronization signal is generated from the line flyback.

Figure 12

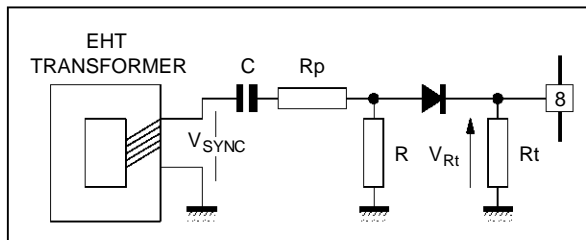

5170-22.EPS

The pulse amplitude is given by :

$$\frac{V_8 (max)}{V_{SYNC}} = \frac{R}{R + R_p} \text{ With } R_t \gg R$$

The pulse time constant is $(R + R_p)C$ and should be lower than the saw-tooth fall time.

Thus, for a line flyback signal amplitude of 50V :
 $R = 6.8k\Omega$, $R_p = 75k\Omega$, $C = 150pF$

Comment :

Practical and theoretical values may differ slightly since the rise time of the line flyback signal is not generally negligible.

IV.6 - Soft-Start Period Duration

In this application, the duration of soft-start is around 20ms,

With :

$$C_{(S-START)} = T_{(S-START)} \times 2 \times 10^{-6} = 47nF$$

Figure 13

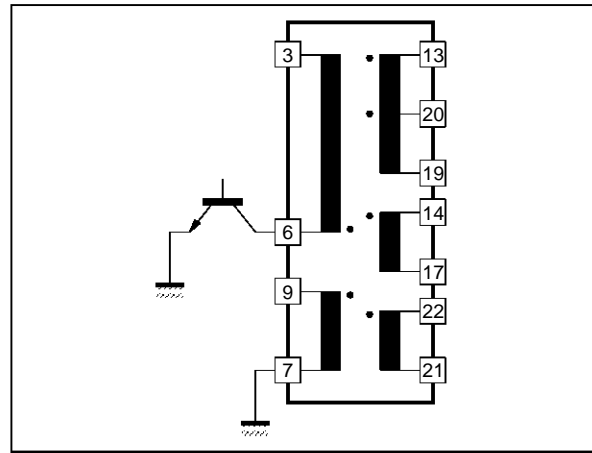

5170-23.EPS

IV.7 - Transformer Characteristics (Reference : G4453-02 OREGA)

Winding	Pin	Inductance
n_P	3-6	680 μH
n_{AUX}	7-9	7 μH
n_2	19-13	592 μH
n_3	19-20	12 μH
n_4	14-17	5 μH
n_5	22-21	25 μH

IV.8 - Operation IV.8.1 - Start-Up

The power supply of TEA5170 begins rising gradually upon initial start-up of the primary circuit. When V_{CC} reaches the value $V_{CC (START)} = 4V$, the oscillator has already begun running and the soft-start capacitor " $C_{(S-START)}$ " begins charging. The conduction time is $t_{ON (min)}$ and rises gradually.

TEA5170 - SECONDARY CONTROLLER FOR MASTER-SLAVE STRUCTURE

IV.8.2 - Stand-By

This function is externally activated by grounding the "stand-by" input thereby disabling the power supply of TEA5170. (Figure 15).

To return to normal mode of operation, this pin should be left floating.

IV.8.3 - Synchronized Mode

The differentiator at synchronization input will transform the line flyback signal into a rectangular pulse whose time constant is around 1ms.

In this mode of operation, there is a lapse of time

between the falling edge of the synchronization signal and the real transistor turn-off (Figure 13).

In TV applications, this time should be less than the line flyback duration so as to avoid the occurrence of on-screen visible disturbances.

t1 and t3 times are specific to TEA5170 (t1 + t3 = 800ns typ.)

t4 is specific to the primary circuit (= 800ns typ. with TEA2164).

Only t2 = tON (min) and t5 = tSTG of the switching transistor can be modified according to individual application requirements.

IV.9 - Delay Time in Synchronized Mode

Figure 14

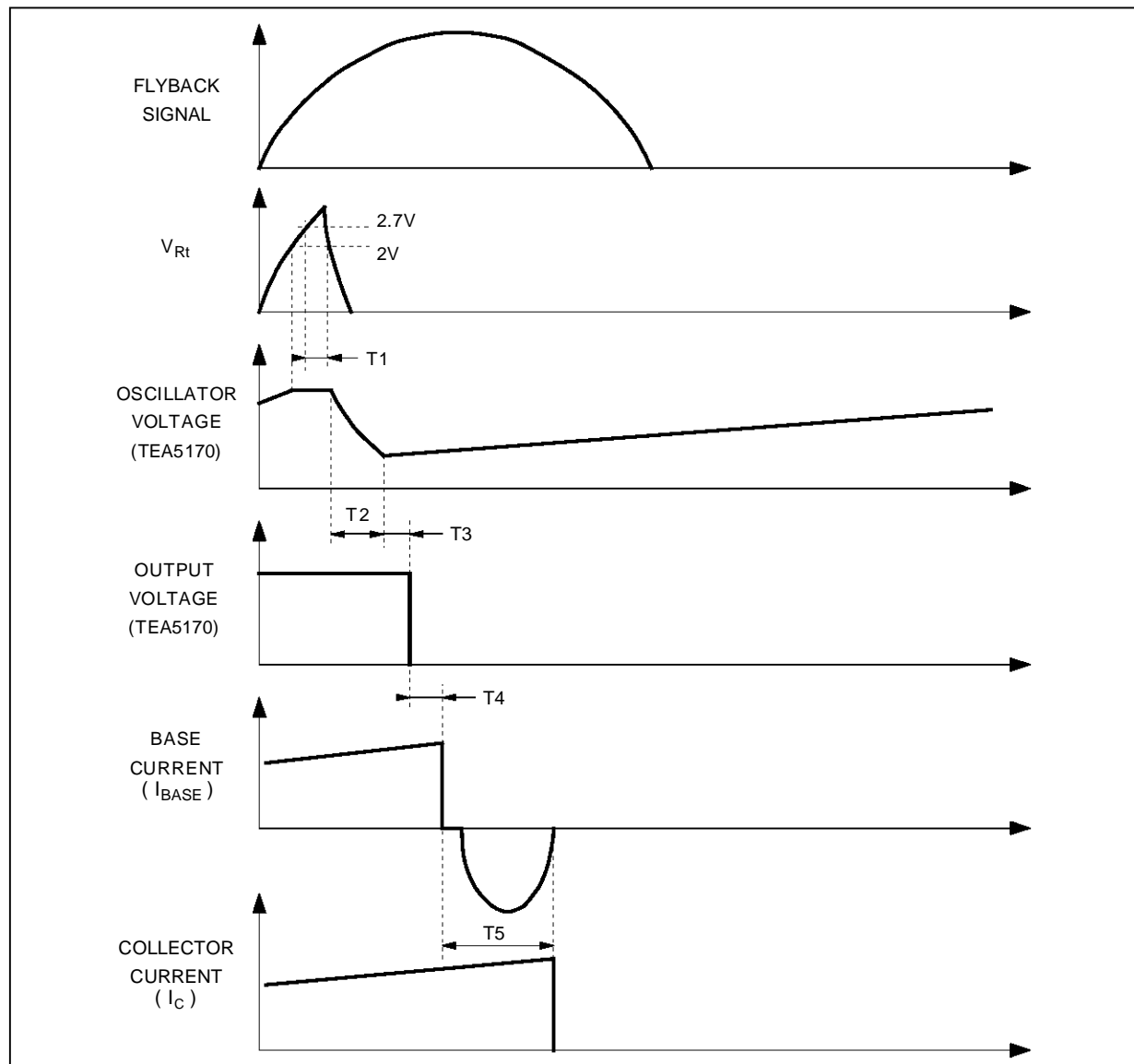

5170-24.EPS

TEA5170 - SECONDARY CONTROLLER FOR MASTER-SLAVE STRUCTURE

IV.10 - Electrical Diagram

Figure 15

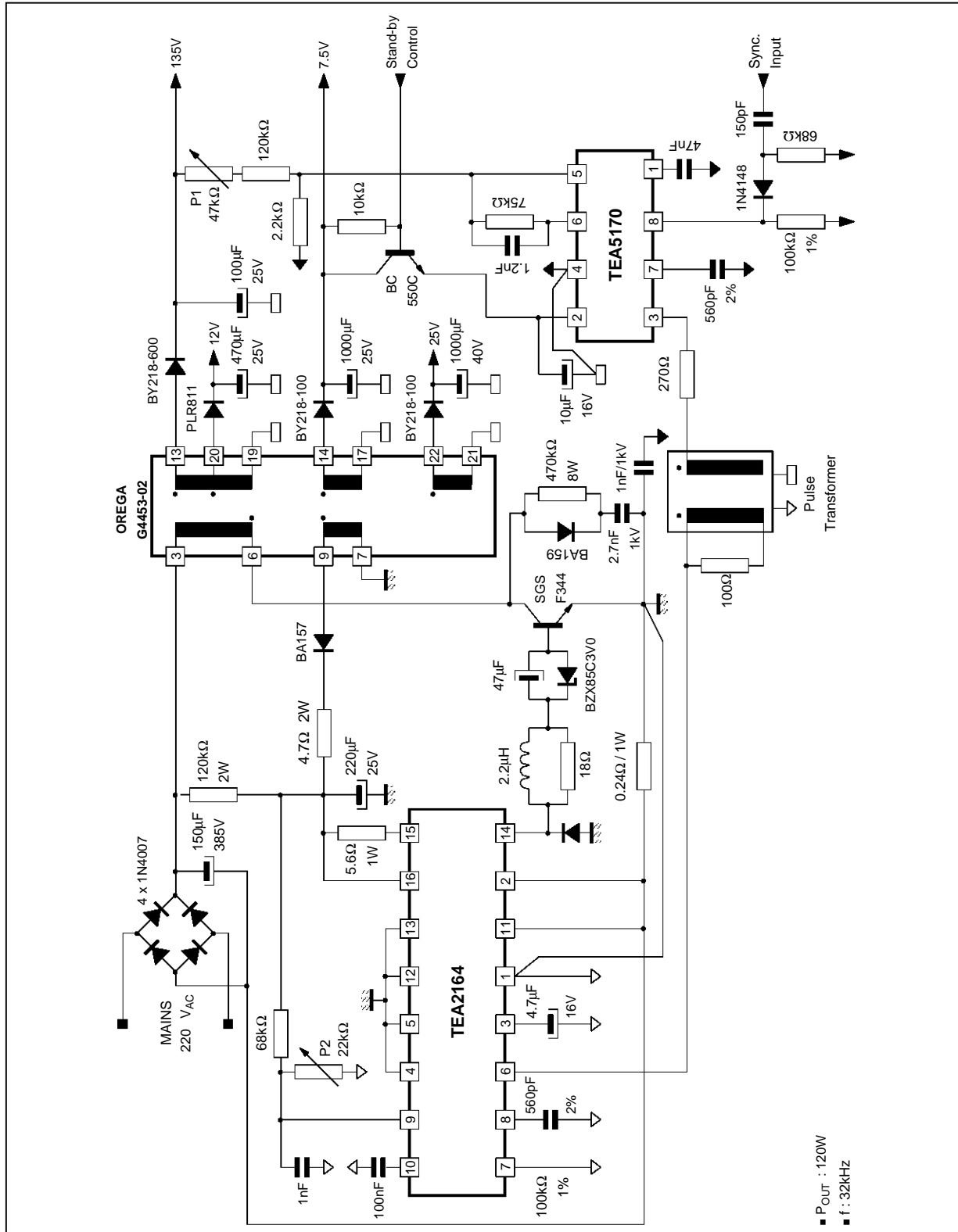

5170-25-EP5

TEA5170 - SECONDARY CONTROLLER FOR MASTER-SLAVE STRUCTURE

V - DC-DC CONVERTER

($9V \pm 40\% \Rightarrow 24V$, 1.5W) (Figure 16)

This low power converter employs a transformer wound on a low-cost ferrite former.

The configuration is protected against open loads and short-circuits.

Transformer characteristics

- Primary inductance : $53.5 \mu\text{H}$
- Transformation ratio for $24V$: $n_S / n_P = 2$

Regulation Characteristics

- Line regulation at $4.9V$ to $15V$: $24V \pm 0.22\%$
- Load regulation for $(0.4P_{\text{max}} - P_{\text{max}})$: $24V \pm 0.12\%$
- Power range : $0.24W$ to $1.6W$
- Efficiency : 40%

V.1 - Electrical Diagram

V.2 - Operation

- The period of operation is determined by R_t and C_t components.
- Minimum conduction duration : $0.6 \mu\text{s}$
- Free-running period : $29 \mu\text{s}$
- Soft-start period duration : preset at 100 ms .

V.2.1 - Open-load Protection

In case of low load values, the minimum conduction

time $t_{\text{ON (min)}}$ with respect to the period of operation is too high to maintain the output voltage at its nominal value. The only solution to stabilize the voltage is to increase the period of operation by reducing the charge current of the oscillator capacitor C_t . This is obtained by injecting additional current into resistor R_t as soon as the output voltage V_{OUT} rises.

V.2.2 - Short-circuit Protection

When the current through transistor becomes substantially high, the transistor is saturated and induces a high di_C/dt . The diode on switching transistor base is then forward biased and begins deviating a portion of the base current. This phenomenon is self amplified and therefore results in rapid transistor turn-off.

V.2.3 - Demagnetization Monitoring

In order to avoid magnetic flux runaway, the transistor should be driven into conduction only once the transformer has been fully demagnetized.

While the transformer is being demagnetized, the secondary-connected rectifier diode is forward biased and thus maintains the error amplifier output at 0 potential. The allowed conduction period is consequently $t_{\text{ON (min)}}$.

Figure 16

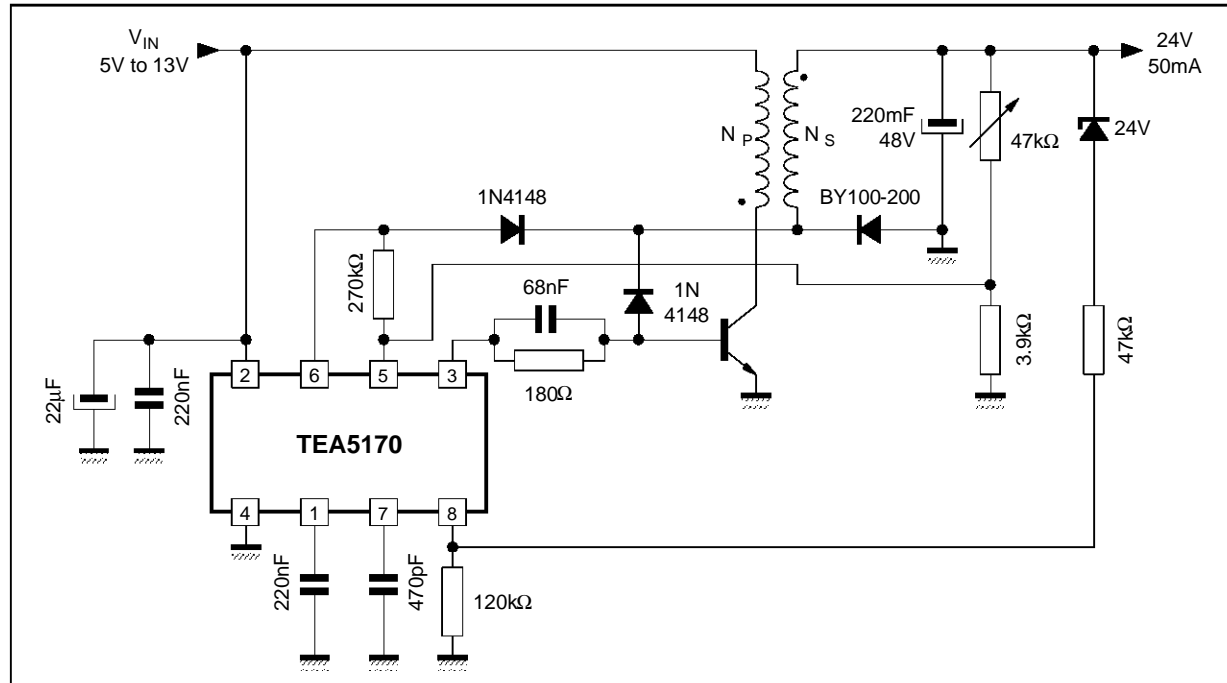

5170-26.EPS

TEA5170 - SECONDARY CONTROLLER FOR MASTER-SLAVE STRUCTURE

VI - CONCLUSION

The TEA5170 requires a very simple configuration and yet offers excellent regulation quality combined with synchronization possibility for flyback-type converters.

The TEA5170 can be used in converters operating at 16kHz to over 100kHz frequency range.

Access to error amplifier and soft-start input are some of the remarkable features offered by this device whose application areas are by no means limited.

The TEA5170 belongs to the family of master controller devices characterized by their outstanding flexibility of use and application performances.

Information furnished is believed to be accurate and reliable. However, SGS-THOMSON Microelectronics assumes no responsibility for the consequences of use of such information nor for any infringement of patents or other rights of third parties which may result from its use. No licence is granted by implication or otherwise under any patent or patent rights of SGS-THOMSON Microelectronics. Specifications mentioned in this publication are subject to change without notice. This publication supersedes and replaces all information previously supplied. SGS-THOMSON Microelectronics products are not authorized for use as critical components in life support devices or systems without express written approval of SGS-THOMSON Microelectronics.

© 1994 SGS-THOMSON Microelectronics - All Rights Reserved

Purchase of I²C Components of SGS-THOMSON Microelectronics, conveys a license under the Philips I²C Patent. Rights to use these components in a I²C system, is granted provided that the system conforms to the I²C Standard Specifications as defined by Philips.

SGS-THOMSON Microelectronics GROUP OF COMPANIES

Australia - Brazil - China - France - Germany - Hong Kong - Italy - Japan - Korea - Malaysia - Malta - Morocco
The Netherlands - Singapore - Spain - Sweden - Switzerland - Taiwan - Thailand - United Kingdom - U.S.A.